



ES12-12WA/ES14-14WA

ES16-16WA

Electric Stacker 1.2-1.6t

Ideal Choice for Heavy Duty Short Distance Handling and Stacking Tasks:
Long-tiller Design Makes Operations Easy and Convenient;
Long aside tiller offers wider view and safer operation.

CALL US TODAY AND TALK TO OUR TEAM OF EXPERTS

0800 619 0800

www.shshandlingsolutions.com

Performance

- The innovative AC system offers strong power, accurate control, excellent performance.
- High strength vertical gearbox, longer working life.
- Low-noise but durable hydraulic unit, good quality cylinder as well as hose ensure the high reliability of hydraulic system.
- AMP connector and durable electric wires greatly reduce malfunctions of components.
- H shape mast channel mast improves the strength of the whole truck.

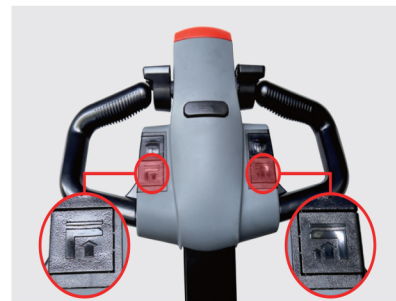

Safety

- Safe hydraulic system design prevents mast from falling down abruptly when hydraulic pipeline cuts off.
- Emergency reverse belly button protects the operator from getting hurt.
- Emergency disconnecter will cut off power source to avoid accident when truck goes out of control.
- Multiple lifting limit protection ensures safety.
- Automatic switch to lower speed when the fork reaches its setting height.
- Anti-rolling back brake keeps the truck from skidding down when truck is out of control or travelling on ramp.
- Long aside tiller reduces operator's hazards.

Operation

- With the new design of ergonomical tiller head, all buttons can be reached conveniently & comfortably.
- Creep speed function: when tiller is in near vertical position, the driving speed will decrease automatically, allowing delicate operation in confined space.
- Long tiller offers easier operation.
- Aside Operation, Greater View.
- Two-speed lowering offers better stability and accuracy of goods stacking.

Maintenance

- AC traction motor, maintenance free.
- Hour meter and battery indicator remind the operator of battery charging.
- Back cover can be removed easily; Access to all key components for inspection, maintenance and replacement.
- Easy access for battery maintenance.
- Vertical motor makes the inspection & service much more convenient.
- Control system allows easy trouble-shooting.
- Mast and chassis are assembled together, easy for maintenance.
- Low voltage cut off setting protects batteries.

Electric Stacker 1.2-1.6t

ES12-12WA/ES14-14WA

ES16-16WA

Distinguishing mark	1.1	Manufacturer			EP	EP	EP
	1.2	Model designation			ES12-12WA	ES14-14WA	ES16-16WA
	1.3	Drive			Electric	Electric	Electric
	1.4	Operator type			Pedestrian	Pedestrian	Pedestrian
	1.5	Load capacity	Q	kg	1200	1400	1600
	1.6	Load center distance	c	mm	600	600	600
	1.8	Load distance, centre of drive axle to fork	x	mm	688	693	693
	1.9	Wheelbase	y	mm	1315	1305	1305
	Service weight	2.1	Service weight		kg	955	1050
2.2		Axle loading, laden front/rear		kg	715/1440	755/1695	780/1890
2.3		Axle loading, unladen front/rear		kg	645/310	715/335	730/340
Tyres/chassis	3.1	Tyre type			Polyurethane	Polyurethane	Polyurethane
	3.2.1	Tyre size, front		mm	Φ230x75	Φ230x75	Φ230x75
	3.3.1	Tyre size, rear		mm	Φ85x70	Φ85x70	Φ85x70
	3.4	Additional wheels (castor wheels)		mm	Φ130x55	Φ130x55	Φ130x55
	3.5	Wheels, number front/rear (x=drive wheels)		mm	1x +1/4	1x +1/4	1x +1/4
	3.6.1	Tread width, front	b10	mm	538	538	538
	3.7.1	Tread width, rear	b11	mm	380/515	360/495	360/495
Dimensions	4.0	Max. Lift Height	H	mm	3000	3000	3000
	4.2	Retracted mast height	h1	mm	1970	2030	2030
	4.3	Free lift	h2	mm	100	100	100
	4.4	Lift height	h3	mm	2912	2912	2912
	4.5	Height, mast extended	h4	mm	3420	3465	3465
	4.6	Initial lift	h5	mm	—	—	—
	4.9	Height of tiller handle in drive position min./max.	h14	mm	715/1200	715/1200	715/1200
	4.10	Height of wheel arms	h8	mm	—	—	—
	4.15	Lowered height	h13	mm	88	88	88
	4.19	Overall length	l1	mm	1826	1940	1940
	4.20	Length to face of forks	l2	mm	676	790	790
	4.21	Overall width	b1/b2	mm	800	800	800
	4.22	Fork dimensions	s/e/l	mm	60x170x1150	60x190x1150	60x190x1150
	4.24	Fork carriage width	b3	mm	—	—	—
	4.25	Distance between fork-arms	b5	mm	550/685	550/685	550/685
	4.26	Distance between wheel arms/loading surfaces	b4	mm	—	—	—
	Performance data	4.31	Ground clearance, laden, below mast	m1	mm	—	—
4.32		Ground clearance, center of wheelbase	m2	mm	28	30	30
4.34.1		Aisle width for pallets 1000×1200 crossways	Ast	mm	2333	2465	2465
4.34.2		Aisle width for pallets 800×1200 crossways	Ast	mm	2303	2440	2440
4.35		Turning radius	Wa	mm	1463	1589	1589
5.1		Travel speed, laden/unladen		km/h	5.0/5.5	5.0/5.5	5.0/5.5
5.2		Lifting speed, laden/unladen		m/s	0.10/0.16	0.13/0.16	0.13/0.16
Electric-engine	5.3	Lowering speed, laden/unladen		m/s	0.19/0.18	0.22/0.13	0.22/0.13
	5.8	Max. gradeability, laden/unladen		%	8/16	8/16	8/16
	5.10	Service brake			Electromagnetic	Electromagnetic	Electromagnetic
	6.1	Drive motor rating S2 60 min		kW	1.1	1.1	1.1
	6.2	Lift motor rating at S3 15%		kW	2.2	3.0	3.0
Addition data	6.4	Battery voltage/nominal capacity		V/Ah	24/210	24/210	24/230
	6.5	Battery weight		kg	190	190	210
	8.1	Type of drive control			AC	AC	AC
	10.5	Steering design			Mechanical	Mechanical	Mechanical
10.7	Sound pressure level at the driver's ear		dB(A)	74	74	74	

If there are improvements of technical parameters or configurations, no further notice will be given.

The diagram shown may contain non-standard configurations.

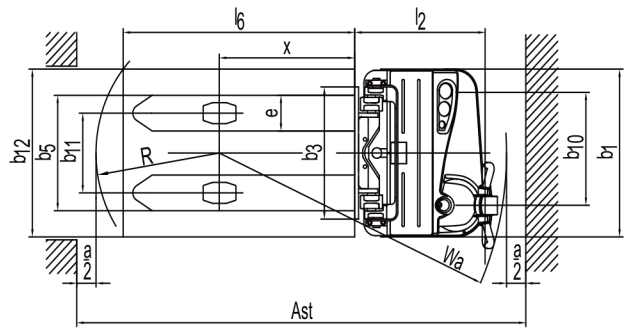
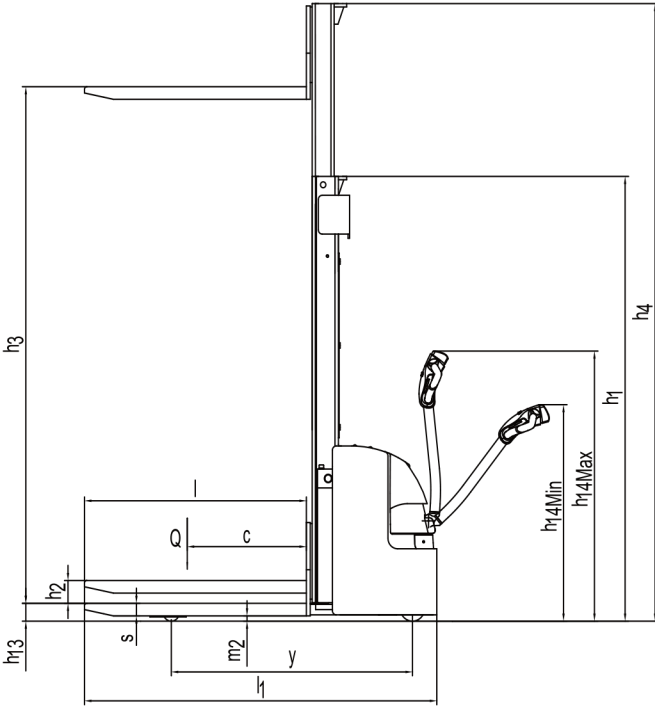

RATED CAPACITIES GRAPH

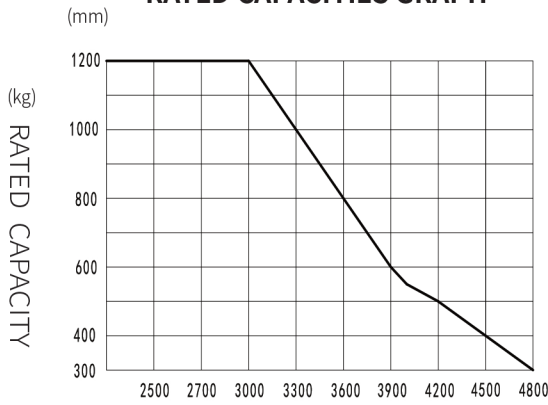

ES12-12WA LIFTING HEIGHT (mm)

RATED CAPACITIES GRAPH

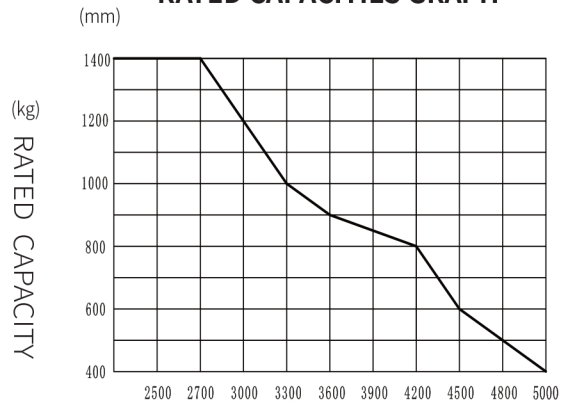

ES14-14WA LIFTING HEIGHT (mm)

RATED CAPACITIES GRAPH

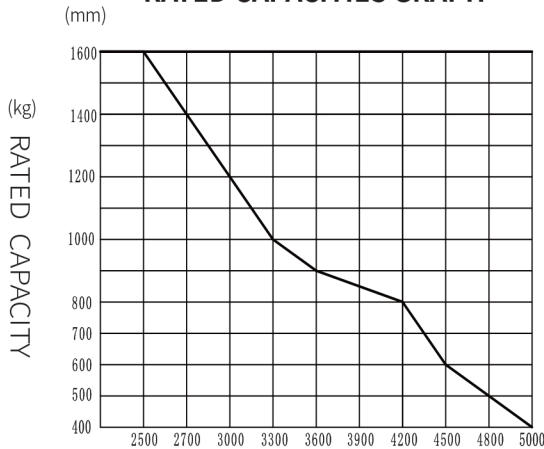

ES16-16WA LIFTING HEIGHT (mm)

Mast Option

ES12-12WA

Mast types	Lift height h3+h13 (mm)	Height, mast lowered h1 (mm)	Free lift h2 (mm)	Height, mast extended h4 (mm)
2-Standard Mast	2500	1720	100	2900
	2700	1820	100	3100
	3000	1970	100	3400
	3300	2120	100	3700
	3600	2270	100	4000
	3900	2420	100	4300
	4170	2550	100	4560
2-Free Mast	2700	1819	1320	3119
	3000	1969	1470	3419
	3300	2119	1620	3719
3-Free Mast	4000	1822	1390	4460
	4500	2022	1590	4960
	4800	2122	1690	5260

ES14-14WA/ES16-16WA

Mast types	Lift height h3+h13 (mm)	Height, mast lowered h1 (mm)	Free lift h2 (mm)	Height, mast extended h4 (mm)
2-Standard Mast	2700	1870	100	3165
	3000	2020	100	3465
	3300	2170	100	3765
	3600	2320	100	4065
	3900	2470	100	4365
	4170	2600	100	4625
2-Free Mast	—	—	—	—
	—	—	—	—
	—	—	—	—
3-Free Mast	4000	1830	1390	4470
	4500	2030	1590	4970
	4800	2130	1690	5270

Option

No.	Optional items	ES12-12WA	ES14-14WA/ES16-16WA
1.1	Fork length	●1150○1220	●1150○1220
1.2	Fork width	●550○685	●550○685
1.3	Fork lowered height	●88	●88
2.1	Load wheel type	●Double	●Double
2.2	Load wheel material	●PU	●PU
2.3	Drive wheel material	●PU○Trace PU	●PU○Trace PU
2.7	Battery capacity	●165Ah○210Ah○230Ah	●210Ah○230Ah
2.8	Charger	●24V-30A External	●24V-30A External
2.9	Battery indicator	●With time	●With time
3.3	Castor wheels	●	●
3.4	Water auto-filling system	○	○
3.7	Warning lamp	○	○
3.9	Blue lamp	○	○
3.12	Hummer	○	○
3.16	Vertical handler working	●	●
4.1	Battery side pull function	●	●
4.5	Proportional lift system	○	○

Note: ● Standard ○ Optional - Inconformity